

Automated energy performance diagnosis of HVAC systems by the 4S3F method

Arie Taal ^a, Laure Itard ^b

^a Department Mechanical Engineering, The Hague University of Applied Sciences, Delft, the Netherlands, actaal@hhs.nl.

^b Faculty of Architecture and the Built Environment, Delft University of Technology, Delft, the Netherlands, l.c.m.itard@tudelft.nl.

Abstract. In practice, faults in building installations are seldom noticed because automated systems to diagnose such faults are not common use, despite many proposed methods: they are cumbersome to apply and not matching the way of thinking of HVAC engineers. Additionally, fault diagnosis and energy performance diagnosis are seldom combined, while energy wastage is mostly a consequence of component, sensors or control faults. In this paper new advances on the 4S3F diagnose framework for automated diagnostic of energy waste in HVAC systems are presented.

The architecture of HVAC systems can be derived from a process and instrumentation diagram (P&ID) usually set up by HVAC designers. The paper demonstrates how all possible faults and symptoms can be extracted on a very structured way from the P&ID, and classified in 4 types of symptoms (deviations from balance equations, operational states, energy performances or additional information) and 3 types of faults (component, control and model faults). Symptoms and faults are related to each other through Diagnostic Bayesian Networks (DBNs) which work as an expert system. During operation of the HVAC system the data from the BMS is converted to symptoms, which are fed to the DBN. The DBN analyses the symptoms and determines the probability of faults.

Generic indicators are proposed for the 4 types of symptoms. Standard DBN models for common components, controls and models are developed and it is demonstrated how to combine them in order to represent the complete HVAC system. Both the symptom and the fault identification parts are tested on historical BMS data of an ATES system including heat pump, boiler, solar panels, and hydronic systems. The energy savings resulting from fault corrections are estimated and amount 25%. Finally, the 4S3F method is extended to hard and soft sensor faults. Sensors are the core of any FDD system and any control system. Automated diagnostic of sensor faults is therefore essential. By considering hard sensors as components and soft sensors as models, they can be integrated into the 4S3F method.

Keywords. 4S3F, FDD, Energy performance, DBN, P&ID

DOI: <https://doi.org/10.34641/clima.2022.183>

1. Introduction

The Heating Ventilation and Air Conditioning (HVAC) sector is responsible for a large part of the total worldwide energy consumption, a significant part of which is caused by incorrect operation of controls and maintenance. HVAC systems are becoming increasingly complex, especially due to multi-commodity energy sources, and as a result, the chance of failures in systems and controls will increase. Therefore, systems that diagnose energy performance are of paramount importance. However, despite much research on Fault Detection and Diagnosis (FDD) methods for HVAC systems, they are rarely applied. One major reason is that

proposed methods are different from the approaches taken by HVAC designers who employ process and instrumentation diagrams (P&IDs). This paper shows how P&IDs can be combined with data from Building Management Systems and Bayesian statistics to identify operation faults and diagnose energy performance.

2. FDD methods for energy performance evaluation of HVAC systems

2.1 Phases of an FDD process

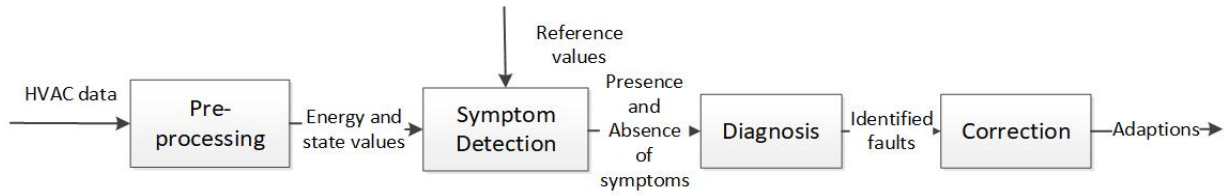

Fig. 1. Phases of an FDD process

In general, a fault analysis process consists of phases as shown in **Fig. 1**.

- Step 1: Pre-processing - Raw data from data loggers or from the building (energy) management system ((B(E)MS) is converted in processable format for FDD as energy data and other metrics. In this stage, incomplete and corrupted data is filtered. Furthermore, values derived from measurements are estimated.

Then, the FDD finds place:

- Step 2: Symptom detection - Presence or absence of symptoms indicating malfunction.
- Step 3: Diagnosis - Faults causing the detected symptoms are identified based on symptoms (see **Fig. 2**) and fault effects on energy performance and comfort are quantified.

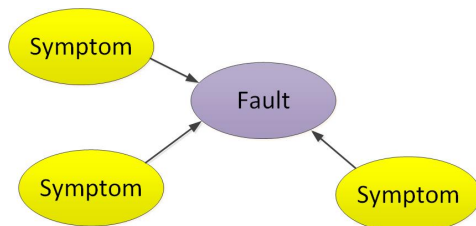

Fig. 2. Isolation of a fault from symptoms

End after diagnosis:

- Step 4: Correction - In this stage decisions are made for repair and adjustments.

The focus in the present paper is on the detection and diagnosis phases.

2.2 Symptom Detection methods

An overview of methods used in such applications is discussed below. First, the different generic types of FDD methods are discussed and **Fig. 3** presents an overview of these methods, derived from Yang [1].

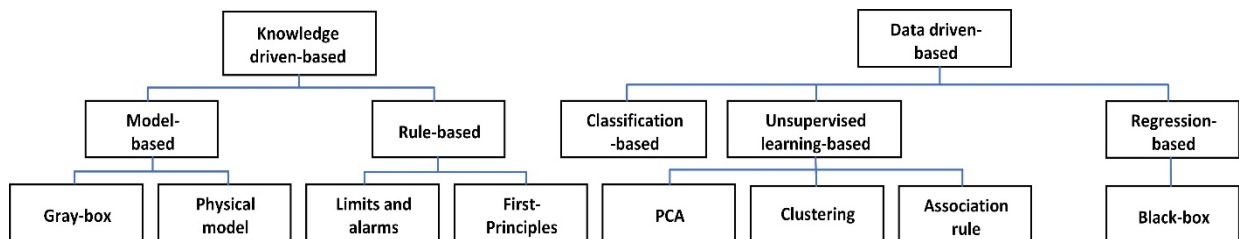

Fig. 3. Classification of FDD methods (Derived from [1]).

They classify FDD methods into quantitative, qualitative, and process history-based methods:

- **Knowledge-driven based** which are based on physical models, e.g., from simulation models (could be detailed) or physical balances (simplified) and are also called **model-based** methods. See for instance [2]. Next to this, **rule-based** methods are applied, e.g., measured temperatures are compared to expected ones [3].
- **Data-driven based** methods have gained in popularity during the last decades. These methods are based on measured data from which patterns are identified. The pattern recognition leads to fault isolation. Several data-driven methods have been proposed. Commonly mentioned are supervised methods using black boxes in which physical output (e.g., energy usage) is calibrated against historical data (e.g., regression methods and artificial neural networks [4]). Next to this unsupervised methods are proposed, such as SVM (support vector machine) which divide a data set in faulty and unfaulty outcomes for the HVAC operation [5] and PCA (principal component analysis) methods [6] which reduce a higher dimensional space of variables into a lower dimensional space.

2.3 Fault Diagnosis methods

Most diagnosis methods are coupled to the applied detection method. For instance, from a PCA method for sensor fault detection the specific faulty sensor can be isolated directly. This lead to many FDD methods for different HVAC components.

All these methods diagnose faults on different levels: from component level to whole system level. When a multi-level approach is present, it is either top-down or bottom-up in sequences incorporating multiple types of methods [7]. It is also noticeable that the diagnosis approach often strongly depends on the detection method used.

For instance, when diagnosing sensor faults using PCA methods there is a one-on-one correlation

between symptoms and faults [6]. Hence, libraries with generic FDD models for all kind of HVAC systems are still missing.

Furthermore, most available FDD methods result in a binary outcome for (presence of) symptoms and faults leading to faulty outcomes by inaccuracies in measurement data and the applied FDD method. Therefore, studies over the past decade have focused on minimizing the false diagnosis results through adapted, complex FDD methods optimized for a specific HVAC component. To overcome this problem, the application of diagnosis methods based on probabilities is promising, like Bayesian statistics, which predict fault chances from presence and absence of symptoms. One of such method is the diagnostic Bayesian network (DBN) method, see [8-10]. The DBN method can also largely overcome the other above-mentioned problems because it can handle with simultaneous multi-level diagnosis, modularity, simple extension of symptoms or faults, little data points, different types of symptoms and faults, and even with contradictory and redundant symptoms.

All considered, most FDD methods are still complex, tens of different methods must be used at subsystem or component level for a specific (unique) building and there is no integration at system level. A reference architecture for HVAC FDD is missing which embeds different methods and structures of the FDD process. However, a DBN-based method seems to be able to overcome problems in other methods.

3. HVAC engineering practices

HVAC system design is based on first principles, like mass and energy balances, and from systems science telling that systems can be divided in subsystems. It is common use to apply schematics which grow from raw to detail (e.g., ASHRAE's handbook [11] and design manual [12]). In the design stage, HVAC designers determine the specifications of the components, sub-systems and systems and their control. They capture it into P&IDs (Process and instrumentation diagrams) in which the main HVAC and control components are represented with all their interconnections as well as all mass (fuel, water, air), electric energy and signal transfer channels, by which thermal energy flows can be easily computed. Guidelines for setting up HVAC modules are available.

Fig.4 shows such a P&ID diagram based on Dutch guidelines for measurement points [13] and hydronic hot water [14] modules. A P&ID contains components (presented as symbols) which are linked by pipes, ducts and signals, and contain sensors (depicted as transmitters) and actuators (e.g., electric motors of valves) which are coupled via controllers. Furthermore, the nominal power of components is often shown (see P_{nom}), and the controlled and designed temperatures and flow rates at design conditions on the P&IDs (T and q_v in the figure). All-over, P&IDs contain information

about components, controls and expected state values which are important for energy performance analysis.

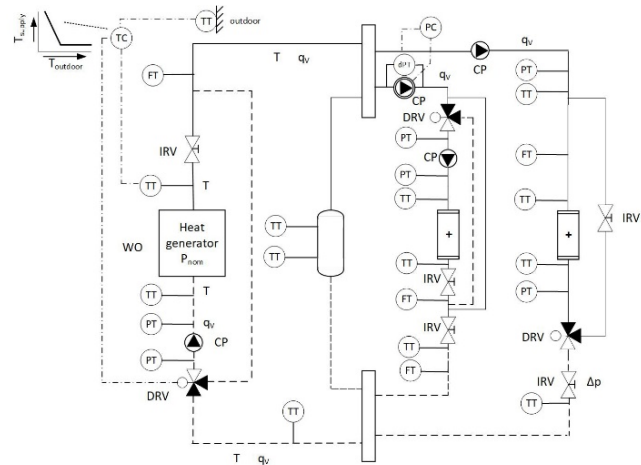

Fig. 4 – Example of a P&ID of a hot water system.

From the P&ID two types of faults can be distinguished: component faults (such as pumps, valves, boilers, sensors) and control faults (settings in controllers, such as TC and CC). Faults of this kind could lead to energy performance (EP) symptoms, such as low coefficients of performance (COPs). From the P&ID, the sensors needed to estimate the exchanged energy amounts for energy performance measures can be estimated. These faults also lead to symptoms such as unwanted temperatures (measured by de sensors TT, CT, PT in the presented P&IDs) or unexpected states of actuators (pumps, valves). These symptoms can be stated as operational state (OS) symptoms. Finally, for the diagnosis to take place with correct measurements, the idea is to use mass, energy, and pressure balance symptoms to rule out sensor errors.

The above types of symptoms and faults are generic, useful, and available for any multi-level HVAC installation and can be extracted from P&IDs.

4. The 4S3F method

Despite much research in this area, major shortcomings result in lack of applications of FDD. Set-up of FDD models is labour intensive because each HVAC system is unique and the set-up demands HVAC, information technology (IT), data analytics, or modelling expertise. IT and data analytics experts have generally little expertise in HVAC, and for them it is difficult to understand the physical meaning of the data they handle. HVAC and building modellers on the contrary lack knowledge on IT and data analytics methods. In addition, FDD methods lack the ability to integrate diagnosis simultaneously on different system levels: component to whole system level. Next to this, most methods are detection methods, which detect that a symptom but do not isolate its causes, the faults. All considered, the HVAC FDD methods are still complex and there is need for a structured approach to FDD, integrating

expertise, components, and methods.

From P&IDs, two types of faults can be extracted: **component and control faults** which lead to three types of symptoms: **energy performance, operational state and balance symptoms**. This was used as a starting point for the development of a novel FDD architecture for HVAC energy performance. The above types of symptoms and faults are generic and usable and available for any HVAC installation at multi-level.

In addition, other symptoms may be available, such as maintenance and inspection information, user complaints, and information from embedded component FDD. However, this information is not always available. It is proposed that this fall under the container term **additional symptom**.

Models have sometimes been drawn up for the symptoms, for example for soft sensors, to determine a value. This also makes faults possible. This is referred to as **model faults**. In [15] a case study is presented that applies this.

4.1 4S3F Architecture

As a result, 4 types of symptoms and 3 types of faults are identified which results in the so-called **4S3F** (4 symptoms and 3 faults) architecture. See Fig. 5.

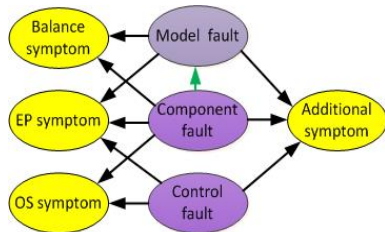

Fig. 5. The 4S3F architecture

This 4S3F architecture was discussed in [16].

4.1 Detection symptoms

In the 4S3F architecture four categories of symptoms are present which are elaborated in [17]. In this paper the symptom detection is applied in a case study.

- Balance symptoms**
These symptoms are based on first principles and are divided in **energy, mass and pressure** balance. Therefore model-based detection methods are applied.
- Energy performance symptoms**
Here, energy performance indicators are applied, such as coefficient of performance (COP) values, **efficiencies** and **capacities** which can be obtained from all types of model-based, rule based methods and data-driven methods.
- Operational state symptoms**
Here, we distinguish for instance **control-based** symptoms, such as deviating supply

temperatures and flow rate and **design-based** symptoms as return temperatures. Also included are the operational **states of components** such as an on-off state and a low or high energy exchange.

- Additional symptoms**
In this container term, other kind of symptoms are present. For instance, **maintenance** or **inspection** information, **complaints** from building users and results from trade **component FDD** results.

4.2 Diagnostic Bayesian Networks

Strength of the 4S3F DBN is that it mimics the way HVAC experts diagnose.

From a P&ID a DBN model can be setup which has to done once. In this model the faults are linked to the symptoms. See Fig. 6 which is based on [18] where diagnosis based on DBN's was discussed. In the showed blue nodes, DBNs of subsystems are present which supports simultaneous diagnosis at multi

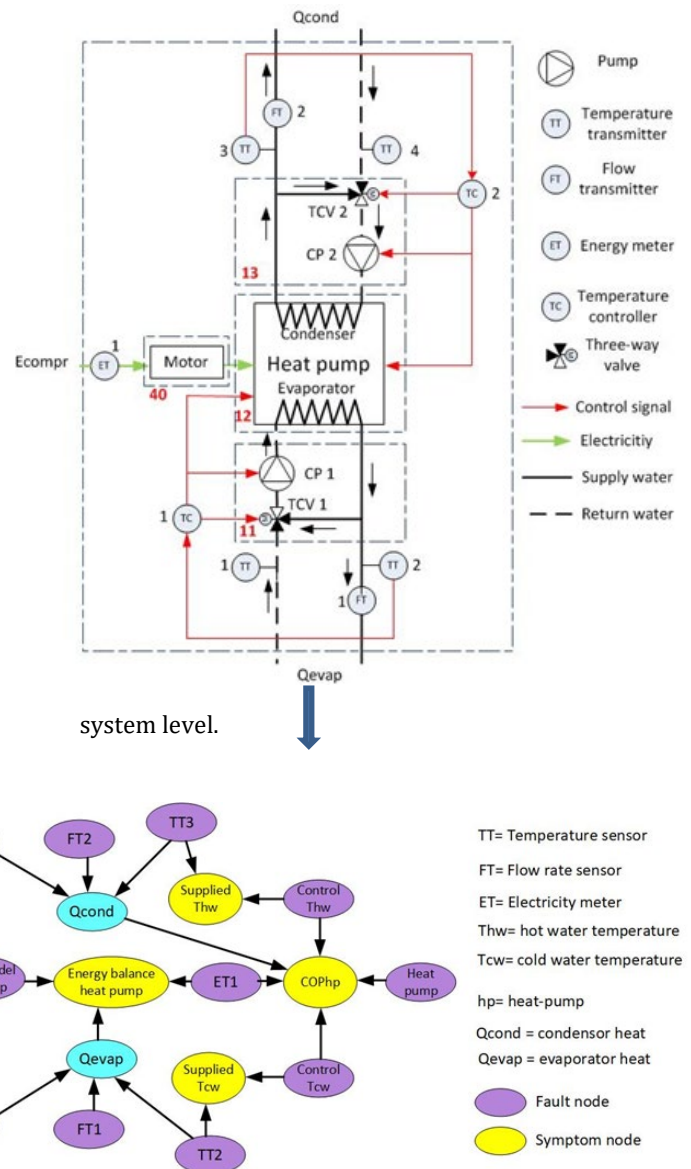

Fig. 6 DBN model extracted from the P&ID.

In de DBN fault nodes, a prior probability for the faults are set and in the DBN symptom nodes, conditional probabilities which means that when more than one fault is linked to a symptom a weighting factor can be assigned.

At operational stage, the DBN is fed by presence or absence of the symptoms. Then the DBN estimates the posterior probabilities of all faults. The HVAC engineer can take action then.

5. Case studies

Case studies were conducted on an actual HVAC system with real measurement data from The Hague University of Applied Sciences (THUAS) building in Delft.

5.1 The building of The Hague University in Delft

This building mainly contains classrooms, offices for lecturers and other staff members, and a restaurant. It was selected because it has a complex HVAC system with an advanced control system, and extensive measurement data is available for analysing energy consumption and indoor climate. In addition, it is an operational HVAC system with a reputation for working properly and apparently being energy efficient. In winter, heat is generated by a heat pump. When the heat loads are high, a gas boiler can deliver additional heat. The heat source of the heat pump is warm ground water delivered by the warm well of an ATES (Aquifer thermal energy storage) system. The ATES system can also deliver heat to the parking lanes on the roof to keep it free of ice. In the summer months, cold water from the cold well of the ATES system delivers cooling. When cooling loads are high, the heat pump produces additional cold at the evaporator side. During the summer, heat from the heat pump condenser and the roof collector can be used to regenerate the warm well of the ATES system, as the annual thermal energy extracted from and pumped into the wells has to be balanced under the Dutch regulations. Cold and heat are delivered to the rooms of the building by a thermal floor system which acts as a Thermally Activated Building System (TABS) and by ceiling radiation panels where hot or cold water is circulated. The hot and cold-water groups are divided in south and north groups which are further divided into sub-groups for the air handling in de air handling units, the ceiling and the floor equipment. A demand driven air ventilation system (DCV system) is present in which the air flow rates to the rooms are controlled by CO₂ concentration and occupancy.

5.2 Results

Studies were conducted on the thermal energy plant and the DCV system for a lecturer room. The 4S3F method was applied for energy performance purposes [17-18] as well for isolating soft and hard

sensor faults. Additionally it was conducted on an air supply system for a room [19]. This three case studies showed that the 4S3F method isolated faults correctly. Furthermore, the studies were conducted as well on energy performance diagnosis as on component FDD and model FDD, for instance soft sensor faults, were elaborated.

As example we show the results from the 4S3F method for the energy plant (presented in [18]). It is discussed by Fig. 7.

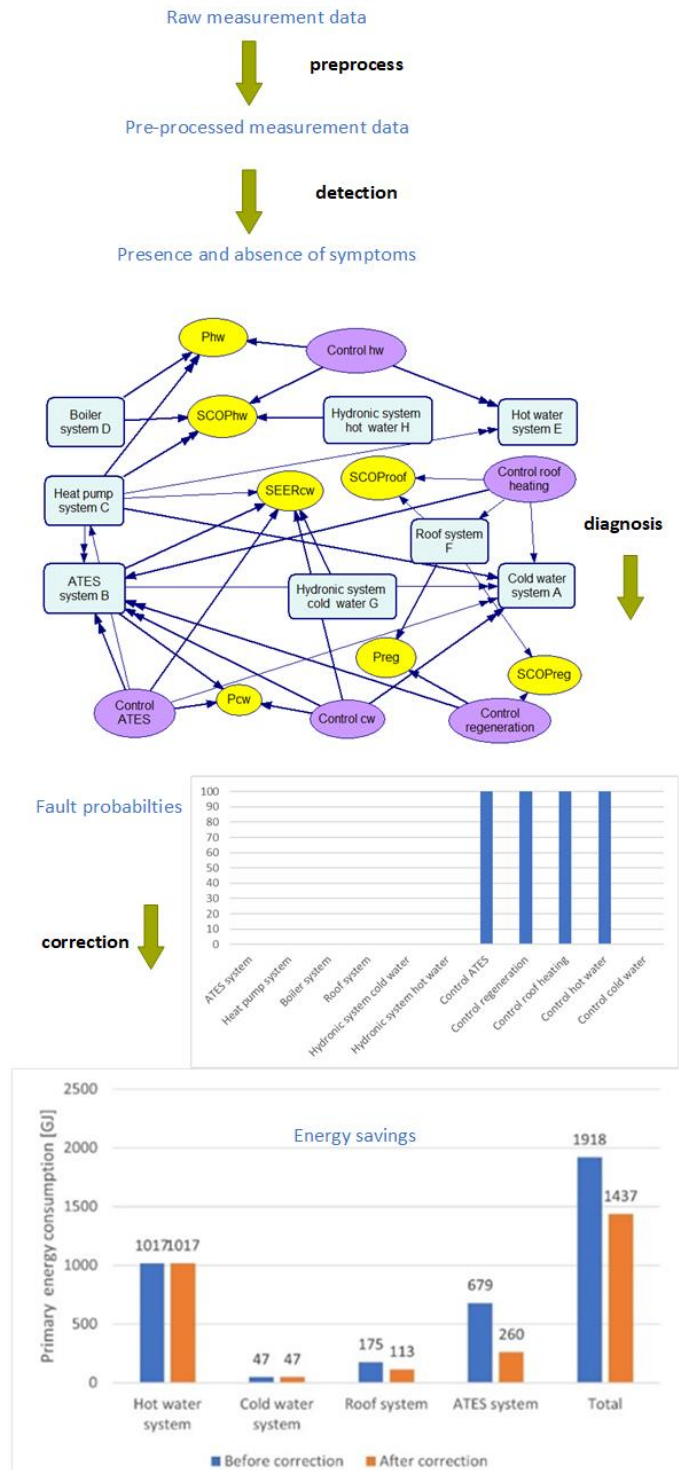

Fig. 7. The 4S3F method applied on the thermal energy plant of THUAS.

Raw measurement data were obtained from the building management system of THUAS. First, this data was **pre-processed** in the correct form for symptom detection. In the case studies, the data was labelled in the correct form (CSV-file), outliers were corrected and missing daily energy data were replaced by results from regression equations. This is common use for measurement data. For 4S3F purposes, soft sensors for missing measurement points (temperatures, flow rates and flow directions) were estimated and energy amounts were estimated. In the next step, the **detection** of balance, energy performance and operational state symptoms have taken place. The results of the detection is fed to a DBN application (GeNie) which **diagnosed** (isolated) the posterior fault probabilities. In this case study it was shown that 4 control faults were present during the measurement period (1 year) with fault probabilities of 100%. Then a theoretical exercise has been conducted on the effect of correcting faulty controls. This is easy to do because the energy amounts were already available from the balance and energy performance symptoms. **Correction** of the control faults resulted in 25% primary energy savings (1437 instead of 1918 GJ).

In all studies, a sensitivity analysis was performed on the set probabilities in the DBN nodes. They showed that, although the resulting fault probabilities varies a bit, the fault identification results were unaffected over a wide range of set probabilities. Only relative differences between them (e.g. that some temperature sensors break more often than other ones etc.), generally known to HVAC experts, matter.

6. Conclusions from the case studies and recommendations

6.2 Conclusions

The main conclusions from the case studies were

- a) P&IDs can be used as the starting point for setting up an energy performance diagnostic system.
- b) Energy performance diagnosis can be conducted with DBNs.
- c) The 4S3F DBN mimics the way HVAC experts diagnose.
- d) It is possible to apply results from model-, rule- and data driven based FDD methods in the 4S3F DBN.
- e) The simultaneous diagnosis at multi-level is supported by the 4S3F DBNs.
- f) Many faults can be isolated at the same time.
- g) The simultaneous redundant detection using balance symptoms on aggregated systems and associated subsystems improves the isolation of the faults.
- h) The 4S3F architecture supports energy performance diagnosis of a thermal energy system as well a DCV system.
- i) Integration of energy performance diagnosis with component FDD is new.
- j) Uncertainties in the FDD method and inaccuracies in the measurement data can be processed in the 4S3F method.

k) Application of model faults, especially soft sensors, in an FDD method is new.

l) Absolute set probabilities of the fault and symptom nodes of the 4S3F DBN are less important than the relative ones.

m) A start to classify rules for energy performance, balance and operational state symptoms was made.

6.2 Recommendations

A start was made to automate the 4S3F method which resulted in the automation of the fault detection and diagnosis. However, automation of the pre-process and correction was not considered. Next to this the automatic set up of the DBN from a P&ID and the feed of symptom detection output were not elaborated. In the case studies libraries of symptoms and DBNs were presented which should be extended for HVAC systems which were not considered yet, such as air handling units, thermal emitter systems, solar energy systems and hydrogen installations. In the Dutch project Brains for Buildings (B4B) [20] the 4S3F method will be elaborated further.

7. References

- [1] Y. Zhao, T. Li, X. Zhang, C. Zhang, Artificial intelligence-based fault detection and diagnosis methods for building energy systems: Advantages, challenges and the future. *Renewable and Sustainable Energy Reviews* 109 (2019):85-101. <https://doi.org/10.1016/j.rser.2019.04.021>.
- [2] J. Bynum, D. Claridge, J. Curtin, Development and testing of an Automated Building Commissioning Analysis Tool (ABCAT). *Energy and Buildings* 55 (2012):607-617. <https://doi.org/10.1016/j.enbuild.2012.08.038>.
- [3] J. Schein, S.T. Bushby, A Hierarchical Rule-based Fault Detection Diagnostic Method for HVAC Systems, *HVAC&R Research* 12 (2006): 111-125. <https://doi.org/10.1080/10789669.2006.10391170>
- [4] Z. Du, B. Fan, X. Jin, J. Chi, Fault detection and diagnosis for buildings and HVAC systems using combined neural networks and subtractive clustering analysis, *Building and Environment* 73 (2014):1-11, <https://doi.org/10.1016/j.buildenv.2013.11.021>
- [5] K. Sun, G. Li, H. Chen, J. Liu, J. Li, W. Hu, A novel efficient SVM-based fault diagnosis method for multi-split air conditioning system's refrigerant charge fault amount, *Applied Thermal Engineering* 108 (2016): 989-998. <https://doi.org/10.1016/j.applthermaleng.2016.07.109>.
- [6] F. Xiao, S. Wang, X. Xu, G. Ge, An isolation enhanced PCA method with expert-based multivariate decoupling for sensor FDD in air-conditioning systems. *Applied Thermal Engineering* 29 (2009): 712-722. <https://doi.org/10.1016/j.applthermaleng.2008>.

[03.046](#)

- [7] D. Choiniere, DABOTM: A BEMS assisted on-going commissioning tool. Proceedings of the National Conference on Building Commissioning (2008).
- [8] Y. Zhao, J.Wen , F. Xiao, X. Yang, S. Wang, Diagnostic Bayesian networks for diagnosing air handling units faults – part I: Faults in dampers, fans, filters and sensors. *Applied Thermal Engineering* 111 (2017): 1272-1286. <https://doi.org/10.1016/j.applthermaleng.2015.09.121>
- [9] Y. Zhao, J. Wen, S. Wang, 'Diagnostic Bayesian networks for diagnosing air handling units faults – Part II: Faults in coils and sensors,' *Applied Thermal Engineering* 90 (2015): 145-157. <https://doi.org/10.1016/j.applthermaleng.2015.07.001>.
- [10] Y. Zhao, S. Wang, An intelligent chiller fault detection and diagnosis methodology using Bayesian belief network. *Energy and Buildings* 57 (2013):278–288. <https://doi.org/10.1016/j.enbuild.2012.11.007>
- [11] ASHRAE Handbook, HVAC Systems and Equipment. American Society of Heating, Refrigerating and Air Conditioning Engineers (2012). ASHRAE.
- [12] Air-Conditioning System Design Manual, Second Edition (2007). ASHRAE Press.
- [13] Meetpunten en meetmethoden voor klimaatinstallaties (2014), ISSO-publicatie 31, Stichting ISSO, Rotterdam, The Netherlands.
- [14] Ontwerp van hydraulische schakelingen voor verwarmen (1998), ISSO-publicatie 44, Stichting ISSO, Rotterdam, The Netherlands.
- [15] A. Taal. A new approach to automated energy performance and fault detection and diagnosis of HVAC systems. PhD thesis. *Bouwstenen* 325. Eindhoven University of Technology. November 2021. ISBN 978-90-386-5409-6.
- [16] A. Taal, L. Itard, W. Zeiler, A reference architecture for the integration of automated energy performance fault diagnosis into HVAC systems, *Energy & Buildings* 179 (2018) 144-155. <https://doi.org/10.1016/j.enbuild.2018.08.031>
- [17] A. Taal, L. Itard, P&ID-based symptom detection for automated energy performance diagnosis in HVAC systems. *Automation in Construction* 119 (2020),103344. <https://doi.org/10.1016/j.autcon.2020.103344>
- [18] A. Taal, L. Itard, P&ID-based automated fault identification for energy performance diagnosis in HVAC systems: 4S3F method, development of DBN models and application to an ATES system. *Energy and Buildings* 224 (2020): 110289. <https://doi.org/10.1016/j.enbuild.2020.110289>
- [19] A. Taal, L. Itard, Fault detection and diagnosis for indoor air quality in DCV systems: Application of 4S3F method and effects of DBN probabilities. *Building and Environment* 174 (2020),106632. <https://doi.org/10.1016/j.buildenv.2019.106632>
- [20] Brains for building's energy systems (B4B). <https://brains4buildings.org>.

The datasets generated during and/or analyzed during the current study are not publicly available as explanations are needed to apply them, but are available after contacting the first author.